

Operation of Microgrid Using an Advanced Converter

Jyoti Pradhan¹, Syed Uvaidullah²

¹Mtech Scholar, LNCTE, Jyotipradhan57@gmail.com, Bhopal, India

² Associated Professor, LNCTE, Bhopal, India

Abstract – The advantages of microgrids in terms of transmission and distribution have significantly increased their popularity over the past decade. Despite notable progress, several questions persist, and issues related to microgrids must be addressed before full commercialization. Among these, two crucial aspects are the supply-demand gap and the efficiency of microgrids. Various research and development activities have yielded diverse microgrid solutions.

To address the increasing power generation capability, adopting a strategic framework that can be utilized for perspective generation and associated loads, either as a subsystem or a microgrid, is essential.

Microgrids incorporate various distributed generation technologies, including micro turbines, fuel cells, photovoltaic systems, wind turbines, and other advanced components such as batteries, capacitors, and flywheels. Efforts in research and development have resulted in a range of microgrid solutions that leverage these technologies.

Keywords: Microgrid, Transmission, Distribution, Supply-Demand Gap, Efficiency, Commercialization, Research and Development, Power Generation, Perspective Age, Distributed Generation Technologies

I. INTRODUCTION

An electric power industry is in the mid of a basic period in its development. Huge scale changes in both transmission and levels of distribution are dependent on future developments power generation is the most prominent factor deciding economic growth and advancement of this particular industry. Sectors of Indian power system are confronting a number of difficulties and in spite of noteworthy development in age throughout the years, it has been experiencing lack of advancements and supply requirements. To address the energy difficulties and make a 21st century imperative economy, we need a 21st century electric framework or roadmap. In appropriation levels, numerous small sustainable generators are associated with the system. Non-renewable energy sources are non-renewable, they basically functions on limited resources which are gradually decreasing, winding up excessive cost or excessively naturally harming to recover. This powers the utilization of numerous kinds of sustainable power source assets–, for example, wind and sun based energy management systems. Sustainable power sources are utilized to reduce the use of less available resources. Right now, the utilization of sustainable sources will counteract obliteration of the earth. Use of individual distribution generators can cause the same number of issues as it is frequently used for various purposes. A superior method to understand the rising capability of power generation is to adopt a framework strategy which can be utilised for perspectives age and related loads as a subsystem or a —microgrid. Microgrids utilize different appropriated age innovations, for example, miniaturized scale turbine, power device, photovoltaic framework, wind turbine together with different advanced resources like battery, condenser and flywheel.

There are a few reasons why microgrids are so intriguing. To begin with, in light of the fact that they include elective strength sources, and the most elective sources offer far higher productivity and less ecological issues than standard power generation. Furthermore, as they are to be on the site which they are to supply, misfortunes because of transmitting power is relatively disposed of .It can give high caliber, continuous power. At the point when such a few sources are associated with structure microgrid, the framework conduct is unpredictable.[3]

Today the demand of electricity is increasing day by day and because of this increasing demand the conventional sources of electricity are converting into non-conventional energy sources. The

need to decrease the hazardous gases and increasing demand of electricity is increasing everyday because of that execution of the renewable energy generators in electrical grids becoming necessary. To minimize greenhouse emissions and fuel consumptions, the best solution is the use of solar photovoltaic or wind generators.

In India, the regional energy development agencies, Ministry of New and Renewable Energy (MNRE) and also some private sector are participating together for the growth of renewable energy. To operate extensive utility grid or associate electrical island, we are using the Microgrid which is an electrical system that involves multiple loads adding distributed energy sources such as PVS, WTGS, diesel generators, fuel cells etc. The usage of these microgrids will help in reducing the supply – demand gap and develops the consumption of renewable energy resources.

The EMS could be a system of which operates with the help of an computer-aided tools designed to be utilized by specialised person of electrical utility grids to observe, management and optimize the act of generation system. EMS plays a significant role in systems of microgrids due to presence of intermittent sources of energy. Following this introduction, an overview of the dc microgrid is given. a way is developed for planning of generation and load.[5]

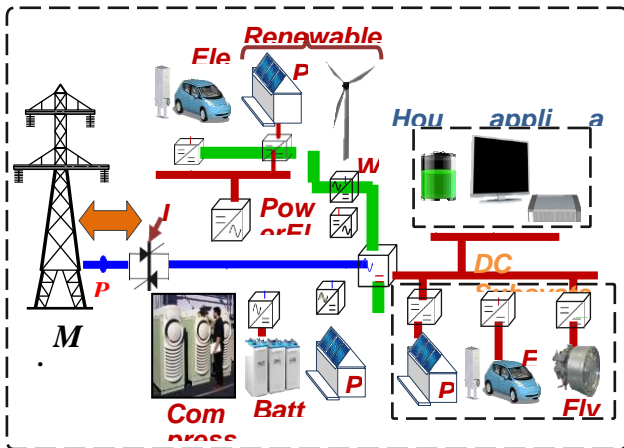

Figure 1 Interfacing between Micro-grid and core utility Grid

II. METHOD

The methodology of Energy Management System in microgrid is specified in various literatures based on multi agent system, inverter based control strategy and voltage droop based energy management. The stepwise procedure for microgrid with proposed modified energy management unit that interacts with interconnection switches is given below. In this dissertation work the system is measured for 2 kW with 1 kW of wind turbine energy generation and photovoltaic generation each.

Step 1: Development of basic microgrid wanting Energy Management System in MATLAB software consisting of following elements

- a) Photovoltaic array as variable source
- b) Wind turbine generation system as variable source
- c) Rectified output utility grid system
- d) Battery storage system using charging and discharging controller

e) Power electronics converters like choppers

Step 2: Connection of DC load such as lamp load, motor load to the microgrid by considering it as variable load and observation of power flow from altered energy sources used.

Step 3: Development of battery model in combination of State of Charge monitoring as a back-up generation just in case of insufficient generation from wind turbine plus photovoltaic to deliver the load. Capacity of battery storage device such as to share approximately 61 % of total load.

Step 4: Development of algorithm for proposed Microgrid Energy Management System in MATLAB software for stepwise interconnection of various energy sources available in microgrid to load for full consumption of every kind of generation to block up the load require.

Closed Loop Boost Converter Model in Simulink

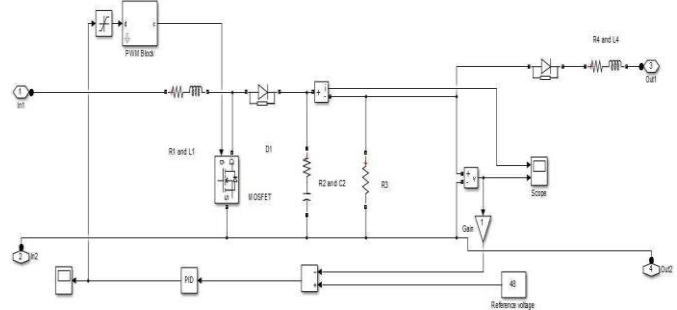

Figure. 2 Model of Closed loop boost converter

The closed loop boost converter for converting 36 V to 48 V constant is shown in Dia. 4.6. The feedback control is provided to the converter by using professional integral derivative (PID) controller. The input voltage commencing the PV and WTGS is of 36 V, it is important to be converted into the bus voltage that is 48 V. MOSFET is used as switch whose switching frequency is 25 MHz. And its duty ratio is changed conferring to the feedback created by the PID controller. A diode with series inductance is connected for unidirectional power flow.

Converter Parameters Design:

The principal step to calculate the control current is to work out the duty cycle, D, for the minimum input voltage. The least input voltage is employed as a result of this leads to the most switch current [15].

Input Voltage Range: $V_{IN(min)}$ and $V_{IN(max)}$ is 20 V and 36 V respectively
 Nominal Output Voltage: V_{out} is 48 V and

Maximum Output Current: $I_{out(max)}$ is 22A

$$D = 1 - \frac{V_{IN(min)} \times \eta}{V_{OUT}}$$

Where, $V_{IN(min)}$ = least input voltage V_{OUT} = required resultant voltage

η = effectiveness of the converter, e.g. estimated 85%

Therefore the duty cycle for the converter is ranging from 0.15 to 0.75 as per above formula.

The efficiency is supplemental to the duty cycle calculation, because the converter has got to deliver conjointly the energy dissipated. This calculation provides a a lot of realistic duty cycle than simply the equation while not the efficiency factor.

The subsequent step to calculate the utmost switch current is to determine the inductance ripple current. the upper the inductance value, the upper is that the maximum output current due to the Abridged ripple current for elements whatever no inductance ranges are given the following equation could be a good estimate for the proper inductance.

$$L = \frac{V_{IN} \times (V_{OUT} - V_{IN})}{\Delta I_L \times f_S \times V_{OUT}}$$

Where, VIN = distinctive input voltage VOUT = required resultant voltage

fS = least switching frequency of the converter

ΔIL = approximate inductor ripple current, see below

Charge Controller

A charge controller, charge regulator otherwise battery regulator bounds the rate at which electric current is additional to or remove as of electric batteries. It avoids over charging and may shield beside over voltage, which can decrease battery performance or duration, and may stance a security problem. It can to avoid completely exhausting ("deep discharging") a battery, otherwise perform controlled discharges; dependent scheduled the battery technology, to guard battery life span. The terms "charge controller" or "charge regulator" may mention to either a stand-alone device, or to control circuitry combined inside a battery pack, battery-powered device, or battery recharger The function of charge controller is to decide battery, whether to charge or discharge. Depending on the feedback taken from battery parameters like battery state of charge, battery voltage and current charge controller resolve be activated. One more task is to maintain battery voltage as per necessary by the system. By monitoring SOC of battery relay will actuate switch to charge battery. Whenever renewable energy generated is supplementary than the load, battery force charge depends on present SOC of battery. Diode and inductance is worn for unidirectional power flow. Simulation model of charging discharging controller is shown in fig.3.

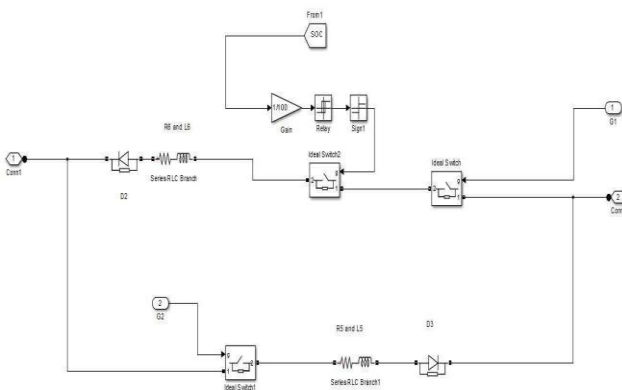

Figure. 3 controller of battery charging

Following parameters are set on the charge controller,

- Charging minimum and maximum voltage range from 45 V to 50V
- Relay setting is on 95 % for charging and 30 % for discharging
- Inductance value of 30 mH and resistance of 0.01 for limiting the charging current
- Diode with 5000 ohm snubber resistance is connected for one way power flow
- Ideal switch for triggering charging plus discharging situations.

III. RESULT

In Simulation results are illustrated for variable generation and load, in which the forecasting data of solar irradiation also wind, are expected to be changeable for the day. The generated power from PV and WTGS are plotted on the same axis, with solar radiation changes from 500 to 1000W/m² plus wind speed changes between 30 to 60 rad/sec of angular speed more over approximately 2 to 5 m/sec linear speed. The simulation is run for 0.1 s.

Condition: 1 Battery Charging

Condition 1, is for battery charging in which the SOC of battery is considered to be 0.3 (30 percent) and variable load coupled to the scheme is between 400W to 1200W. Whenever the load is fewer than generation battery will charge by triggering stationary button of charge controller, additional power generated by the renewable sources will charge the battery. Fig.4 shows generated power plus load and Fig.5. shows battery parameters that is SOC, battery voltage along with current. From 0.05 s battery force initiate charging because required voltage will develop at this point.

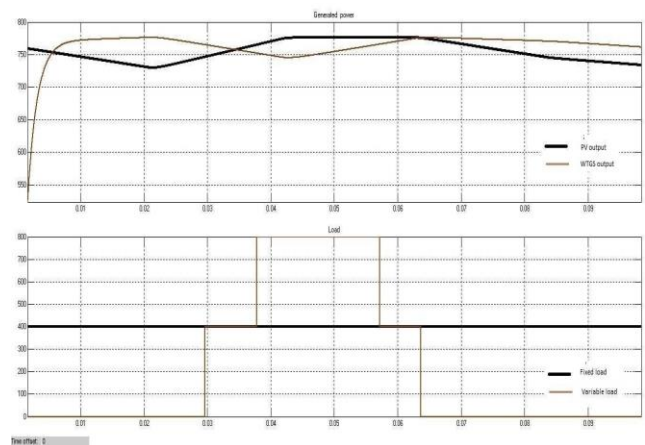

Figure 4 Condition 1 Generated power and load while battery charging

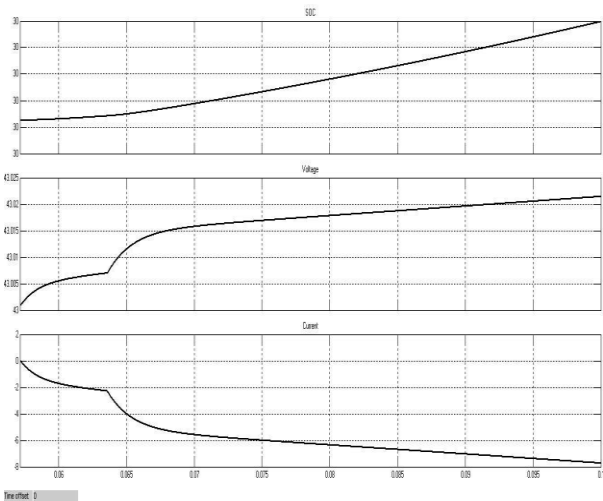

Figure 5 Condition1 battery parameters while charging

Condition: 2 Battery Discharging

Condition 2, is for battery discharging in which the SOC of battery is considered to be above 0.5 (50 percent). Whenever load is higher the generation needs an additional power to complete the load that extra power is getting from the battery. The generated power since renewable is 200 watts to 900 watts and connected load is around 1700 watts. Therefore the additional power needed to supply load is now taken from battery.

Fig.6 shows the graph of generated power along with load and Fig.7 shows Battery parameters. At simulation time 0.01 seconds, the load increases that is exceeds the generation then battery supplies extra power.

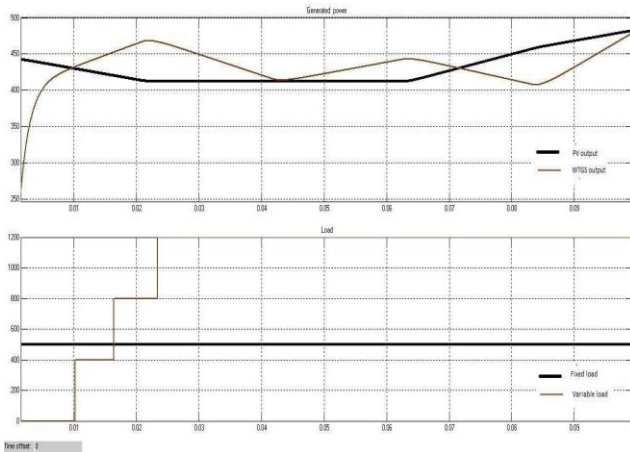

Figure. 6 Condition 2 generated power and load while battery discharging

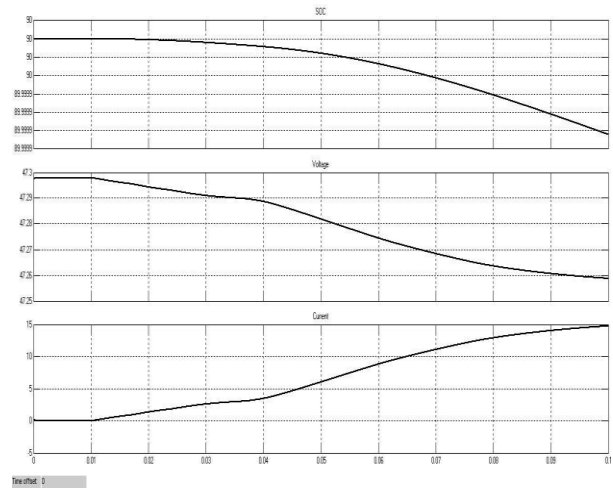

Figure 7 Condition 2 battery parameters while discharging

Condition: 3 Supply Taken From Grid

In condition 3, load is greater than generation and battery SOC is fewer than 0.5 (50 percent), then to supply load power is taken from grid by triggering motionless key connected between dc bus and utility grid whose result is dc 48 V. The generated power at this condition is 100 watts to 1400 watts and connected load is from 500 watts to 1700 watts.

At simulation time from 0.015 seconds the connected load is higher than the generated power, renewables and battery is insufficient to supply increased load, so the required power is supplied by enabling grid. Fig. 8 shows generated power along with load and Fig.9 shows battery parameters. The power given by the utility grid is shown in Figure.10.

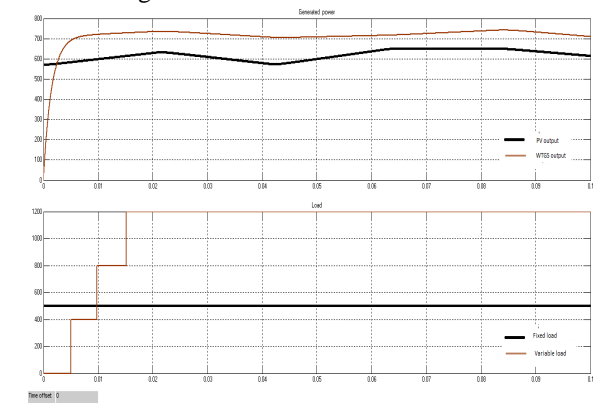

Figure 8 Condition 3 generated power and load while supply taken from grid

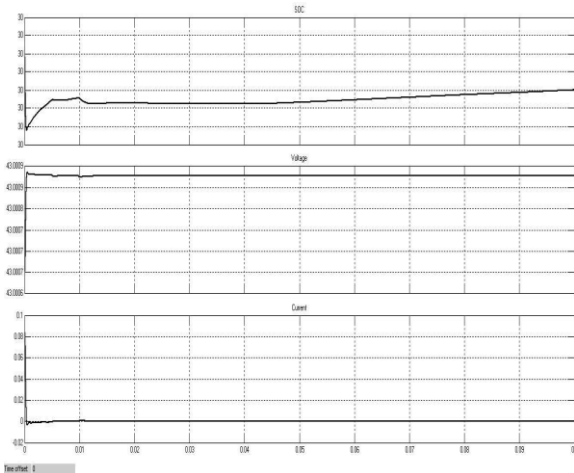

Figure 9 Condition 3 battery parameters while supply taken from grid

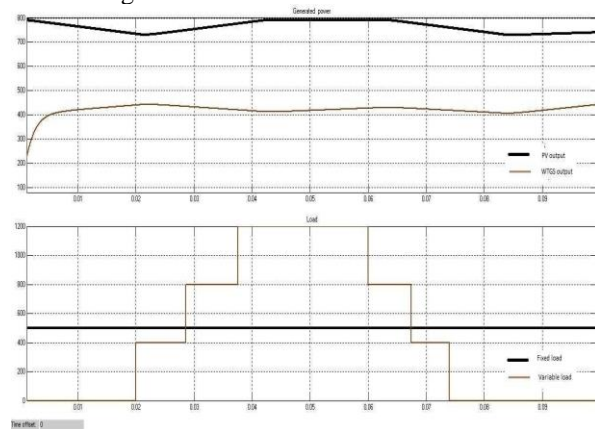

Figure 10 Condition 3 power taken from grid

Condition: 4 PV Maximum and WTGS Minimum

Condition 4, is the condition where PV generation is measured maximum moreover WTGS generation is smallest amount . PV output is assumed to be changeable from 700 watts to 800 watts along with wind turbine generation is from 250 watts to 450 watts. Load is also change able from 500 watts to 1700 watts as shown in diagram. 11 .It preserve be observed from the curvature that, at any time produce power from renewable is additional than connected load, battery charges otherwise discharges whenever itremidies.

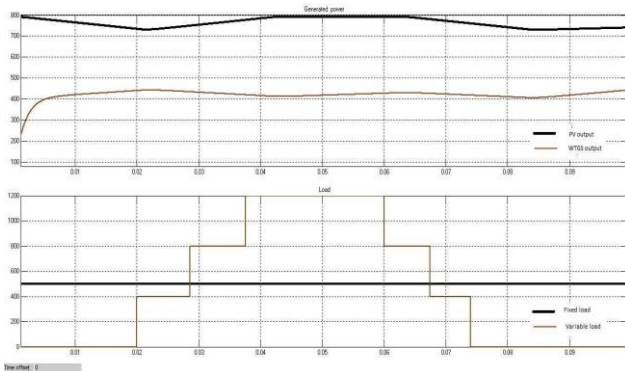

Figure 11 Condition 4 PV at maximum and WTGS at minimum

IV. CONCLUSION

The A simulation model of a microgrid coupled with an energy management system is designed using MATLAB/Simulink software to investigate the dynamics within distributed resources and connected loads. Generation from various renewable sources and the connected load is considered variable. Static switches for each source or load are employed and controlled by gate signals generated by the energy management system. The simulation is conducted under the following conditions:

Maximum power generation from both Photovoltaic (PV) and Wind Turbine Generator System (WTGS) with battery charging.

Minimum power generation from both PV and WTGS with battery discharging.

Average power generation from both PV and WTGS with power taken from the grid.

Maximum power from PV and minimum from WTGS.

Minimum power from PV and maximum from WTGS.

Both PV and WTGS at minimum levels, with the grid inadequate to supply power, resulting in the shutdown of some loads.

References

[1] Anggoro primadianto, "A Review on Distribution System State Estimation," IEEE Transactions on Power Systems, vol. 32, no. 5, Sep. 2017.

[2] L.G. Vasant and V. R. Pawar, "Optimization of solar-wind energy system power for battery charging using MPPT," International Conference on Energy, Communication, Data Analytics and Soft Computing (ICECDS), Chennai, 2017, pp. 1308-1310.

[3] J. Shu, X. Zhang, C. Wu, and Y. Shen, "A significant scheme of distributed generation system using wind-solar-diesel applying in island," 3rd International Conference on Power Electronics Systems and Applications (PESA), Hong Kong, Sep. 2009, pp. 1-3.

[4] R. Nagaraj, "Renewable energy-based small hybrid power system for desalination applications in remote locations," IEEE 5th India International Conference on Power Electronics (IICPE), 07 Feb. 2013.

[5] Ibrahim Elsayed, Ibrahim Nassar, Fatima Motafa, "Optimization and economic evaluation of small-scale hybrid solar/wind power for remote areas in Egypt," 2017 Nineteenth International Middle East Power Systems Conference (MEPCON), 27 Feb. 2018.

- [6] K. A. Rani Fathima, M. L. Bharathi, "A novel grid integration scheme for the hybrid electric power generation using solar and wind energy resources," 2017 International Conference on Computation of Power, Energy Information and Communication (ICCPEIC), 15 Feb. 2018.
- [7] Min Li, Jie Wu, Jun Zeng, La Mei Gao, "Power dispatching of distributed wind-Solar power generation hybrid system based on genetic algorithm," 2009 3rd International Conference on Power Electronics Systems and Applications (PESA), Print ISBN: 978-1-4244-3845-7.
- [8] Lalit Yashwant Bacchav, Asha Gaikwad, "MATLAB implementation of standalone hybrid wind-solar power generation with and without dump power control," 2017 International Conference on Energy, Communication, Data Analytics and Soft Computing (ICECDS), 21 June 2018.
- [9] Ashok Tak, Taha Selim Ustun, "Design of a generic microgrid test bed with novel control and smart technologies," 2015 3rd International Renewable and Sustainable Energy Conference (IRSEC), 21 Apr. 2016.
- [10] Yogesh S. Bhavsar, Prasad V. Joshi, Sonali M. Akolkar, "Energy management in DC microgrid," 2015 International Conference on Energy Systems and Applications, 04 July 2016.
- [11] Ishwari Tank, Shrikant Mali, "Renewable based DC microgrid with energy management system," 2015 IEEE International Conference on Signal Processing, Informatics, Communication and Energy Systems (SPICES), 23 Apr. 2015.
- [12] Md Juel Rana, Mohammad Ali Abido, "Energy management in DC microgrid with energy storage and model predictive controlled AC–DC converter," IET Generation, Transmission & Distribution, vol. 11, no. 15, pp. 3694 – 3702, Oct. 19, 2017.
- [13] Alessio Iovine, Gilney Damm, Elena De Santis, Maria Domenica Di Benedetto, "Management Controller for a DC MicroGrid integrating Renewables and Storages," Elsevier, vol. 50, no. 1, pp. 90-95, Jul. 2017.
- [14] Maheswaran Gunasekaran, Hidayathullah Mohamed, "Energy Management Strategy for Rural Communities' DC Micro Grid Power System Structure with Maximum Penetration of Renewable Energy Sources," Appl. Sci., vol. 8, no. 4, p. 585, Apr. 2018.
- [15] Behnaz Papari, Chris S. Edrington, David Gonsoulin, "Optimal energy-emission management in hybrid AC-DC microgrids with vehicle-2-grid technology," Journal of Renewable and Sustainable Energy, vol. 11, no. 1, Nov. 2018.
- [16] Panbao WANG, "Multi-objective energy management system for DC microgrids based on the maximum membership degree principle," Springer, 4 Dec. 2017.
- [17] Yu-Kai Chen, Yung-Chun Wu, Chau-Chung Song, Yu-Syun Chen, "Design and Implementation of Energy Management System With Fuzzy Control for DC Microgrid Systems," IEEE Transactions on Power Electronics, vol. 28, no. 4, Apr. 2013.
- [18] Brigitte Hauke, "Basic Calculation of a Boost Converter's Power Stage," Application Report SLVA372C–November 2009–Revised January 2014, Texas Instruments.
- [19] S. Devi, R. Saravanapriyan, "Energy Management System Control for a Hybrid Non-conventional Energy Sources using Hysteresis Switching Algorithm," International Journal of Advanced Research in Electrical, Electronics and Instrumentation Engineering, vol. 4, no. 2, Feb. 2015.
- [20] S. Morozumi, "Micro-grid demonstration projects in Japan," in Proc. IEEE Power Converse. Conf., Apr. 2007, pp. 635–642.
- [21] N. Hatziargyriou, H. Asano, R. Iravani, and C. Marnay, "Microgrids," IEEE Power Energy Mag., vol. 5, no. 4, pp. 78–94, Jul./Aug. 2007.